

# ROAD GUARDIAN

## WHEEL WEIGHERS FOR COMMERCIAL VEHICLES

Utilising advanced scale technology, Colonial Weighing Australia introduces the new Road Guardian wheel weigher. Designed as a low profile, self-contained weighing platform, the Road Guardian features a slim, low height platform with totally integrated weighing indicator. Built from aluminium, the individual platform weighs only 15kg with a height of 32mm making it easy to roll vehicles on and off the platforms. The rugged construction of the integrated platform allows it to endure accidental tyre overrun at all points including the digital display area.

All new digital electronics provide a fast, accurate and easy to read weigh indicator that is fully integrated in to the carry handle and is powered by six AA-size batteries located in the display housing. The internal batteries can be recharged from any 12VDC source or the 220VAC line adaptor.

Weight data is displayed on an easy to read alphanumeric liquid crystal display (LCD). The LCD includes backlighting capability for low light or night-time operation. The digital indicator allows the operator to display the weight of each individual platform or the combined weight of all platforms.

The Road Guardian comes in 1, 2, 4 and 6 platform systems to accommodate a variety of different weighing configurations. This can be expanded to interconnect up to 16 platforms in to a single weighing system. The junction box allows up to six platforms to be interconnected and recharge all the internal batteries. Cables are provided to connect each platform to the junction box and power to recharge the internal batteries located in each individual platform.

### Applications

- Weight Enforcement
- On-site Weighing
- Portable Weighing
- Trailer Weighing
- Special Weighing Configurations

### Benefits

- Light Weight and Easy to Handle
- Integrated Digital Indicator
- Portable Operation
- Flexible Weighing Configurations



## Specifications

|                               |  |
|-------------------------------|--|
| Platform Capacity             | 10,000kg x 20kg (20,000lbs x 50lbs)                          |
| Accuracy                      | 0.1% of Full Scale   |
| Graduations                   | 1, 10, 20, 50, 100kg (Menu Programmable)                     |
| Units of Measure              | kg or lbs (Menu Programmable)                                |
| Platform Active Weighing Area | 584mm x 190mm  |
| Semi-Automatic Zero           | Front Panel Zero   |
| Overload Indication           | Meter Indicates Overload Over 10,000kg                       |
| Safe Overload                 | 150% of Rated Capacity                                       |
| Storage Temperature           |  |
| Operating Temperature Range   |  |
| Indicator                     |  |
| Indicator Display             | 16 Character Alphanumeric Dot Matrix Liquid Crystal Display  |
| Indicator Display Lighting    | LCD Back Light Display for Low Light Operation               |
| Indicator Programming         | Front Panel programming and Calibration                      |
| Local / Total Mode            | Single Platform Weight or Total of Multiple Platform Weights |
| Battery Power (Internal)      | 6 x 1.2VDC, AA-Size NiMH Batteries                           |
| Auto Shut-Off                 | After 15 Minutes of Inactivity                               |
| Battery Life (Internal)       | 8 Hours with Full Charge                                     |
| Recharging Time (Internal)    | 16 Hours for Full Charge                                     |
| DC Power                      | Any 12VDC Power Source to Junction Box                       |
| Communications                | RS-232 or 20mA Current Loop for Data Transmission            |
| Single Platform Weight        | 15.5kg   |

## Optional Equipment

|                   |   |
|-------------------|---|
| AC Power Adaptor  | 230VAC, 50-60Hz Power Source to Junction Box          |
| Power Cable       | 12VDC Power Source to Junction Box                    |
| Printer           | L5500 Printer, 12VDC                                  |
| Storage Container | Holds up to 6 Road Guardian Platforms and Accessories |

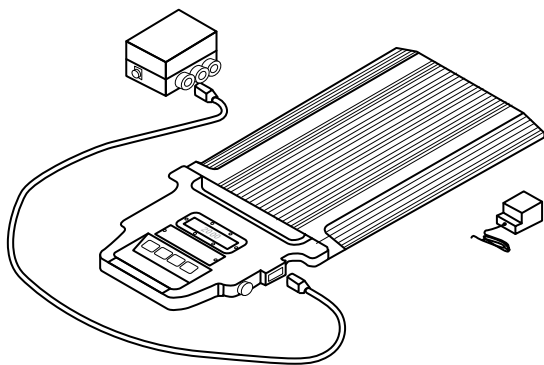

**Road Guardian System**

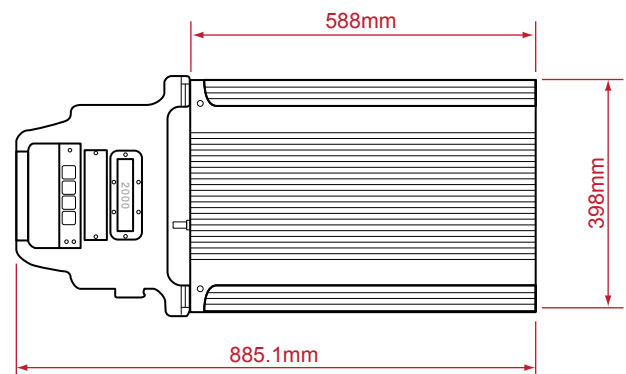

**Overall Dimensions**

## Colonial Weighing Australia Pty Ltd

Unit 11/47-51 Little Boundary Road, Laverton North, Victoria, 3026, Australia

Telephone: (03) 9315 2088  
Facsimile: (03) 9315 2494

[www.colonialweighing.com.au](http://www.colonialweighing.com.au)  
[sales@colonialweighing.com.au](mailto:sales@colonialweighing.com.au)

Established 1930  
ISO 9001 Endorsed