

DESCRIPTION

BASEWORK MADE COMPLETELY OF STAINLESS STEEL AND CONFORMING TO IP-67

Allows washing and water splashing, which realizes easy cleaning and outstanding durability. For the first time in the industry the load cell has been coated with acrylic resin to make it completely waterproof.

AUTO-RANGING FEATURE

Weighing range changes depending on product weight. No need to use several scales for different weighing capacities.

CHECKWEIGHING FUNCTION FOR QUALITY CONTROL

Upper and lower weight limits can be set to check if the product weight is within the specified range. Suitable for controlling the filling quantity of packed food, etc. An optional relay allows for interlock with a display lamp or sequencer.

LARGE, BRIGHT DISPLAY

A large fluorescent display provides superior visibility.

COUNTING FUNCTION

The numeric keypad allows easy operation in counting mode. Single weight and total weight can be displayed at the same time.

RELAY OUTPUT (OPTION)

Linking a lamp or sequencer is also possible by the relay output.



DIMENSIONS

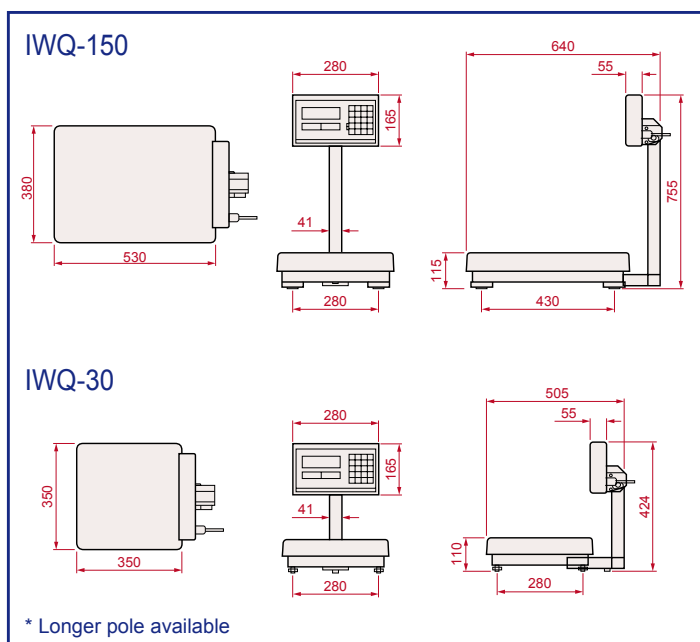

SPECIFICATIONS

MODEL	IWQ-30	IWQ-150
Capacity	30kg/15kg	150kg/60kg
Division	0.01kg/0.005kg	0.05kg/0.02kg
Platter Size	350mm x 350mm	380mm x 530mm
Scale Weight	10kg	18kg

FEATURES

- Fluorescent Display
- Under, Accept and Over Comparator Indication
- IP-67 Basework, IP-65 Display
- Power: 240V \pm 10%, 50/60Hz
- Output via RS232C