

FEATURES

- Heavy-Duty Crane Scale
- Ultimate Load: 500% of Rated Capacity (CS-3T: 350%)
- Two Display Versions:
 - LED Version: 5 x 1" Digits (CS-500 to CS-7.5T)
5 x 1.5" Digits (CS-10T to CS-15T)
 - LCD Version: 5.5 x 25mm Digits (CS-500 to CS7.5T Only,
Include EL Backlighting)
- Equipped with: Power On Zero-Tracking, Rezero Function, Power Saving Function (CS-500 to CS-7.5T Only), Full Tare (Subtractive) Range, Hold Function, High-Speed Average Function
- Metric and Imperial (Upon Request) Weight Units
- Dual Power: Rechargeable Power Pack or Power Adaptor
- Long Battery Operation:
 - 80+ Hours (LED Version)
 - 300+ Hours (LCD Version)
- Free Rotating Hook (CS-500 to CS-3T Only)
- Auto Calibration and Odd Weight Calibration
- Optional Power Pack Provides 24 Hour Non-Stop Operation
- Built-In Rechargeable Battery, External Power Adaptor and Wire Rope Stopper Included



SPECIFICATIONS

MODEL	CAPACITY	DIVISION	ULTIMATE OVERLOAD	NET WEIGHT
CS-500 CS-500-LCD	500kg/10,000lb	0.2kg/0.5lb	500% of Rated Capacity	15kg
CS-1T CS-1T-LCD	1,000kg/2,000lb	0.05kg/1lb		
CS-2T CS-2T-LCD	2,000kg/4,400lb	1kg/2lb		
CS-3T CS-3T-LCD	3,000kg/6,600lb	1kg/2lb		
CS-5T CS-5T-LCD	5,000kg/11,000lb	2kg/5lb		
CS-7.5T CS-7.5T-LCD	7,500kg/16,000lb	5kg/10lb		
CS-10T	10,000kg/20,000lb	5kg/10lb	N/A	92kg
CS-15T	15,000kg/30,000lb	5kg/10lb		
Power Source	Built-in Rechargeable Battery (All Models) or External Power Adaptor (All Models) or Optional Power Pack (CS-500 to CS-7.5T Only)			

DIMENSIONS

MODEL CAPACITY	A	B	C	D	ØE	F	G	H	HOOK
500kg	210mm	160mm	180mm	235mm	65mm	38mm	43mm	228mm	2t
1,000kg	210mm	160mm	180mm	235mm	65mm	38mm	43mm	228mm	2t
2,000kg	210mm	160mm	180mm	245mm	65mm	38mm	43mm	228mm	2t
3,000kg	210mm	160mm	180mm	269mm	65mm	50mm	58mm	228mm	3t
5,000kg	210mm	300mm	200mm	360mm	95mm	55mm	70mm	280mm	8.5t
7,500kg	210mm	300mm	200mm	380mm	95mm	55mm	70mm	280mm	8.5t
10,000kg	305mm	380mm	280mm	485mm	120mm	80mm	80mm	380mm	15t
15,000kg	305mm	380mm	280mm	485mm	120mm	80mm	80mm	380mm	15t

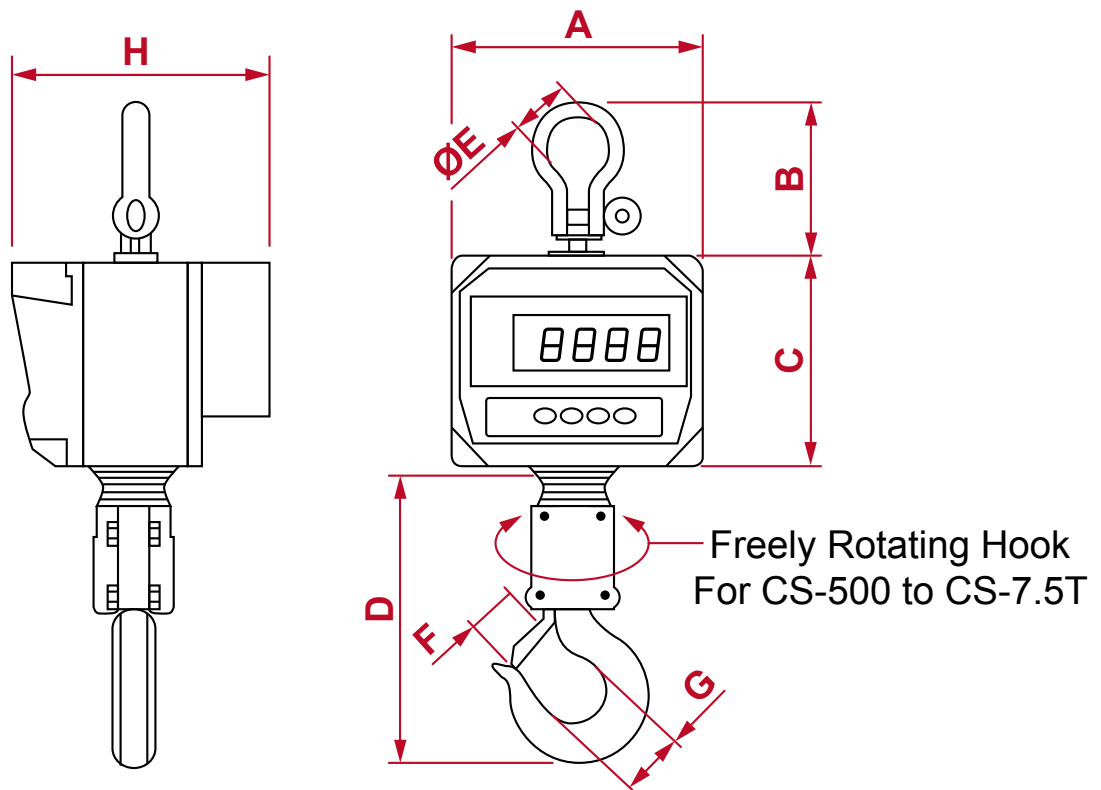

OPTIONS

- Power Pack version (CS-500 to CS-7.5T Only)
- Additional Power Pack
- Wireless Remote Control or Cable Remote Control (LED Versions Only) or Infrared Remote Control (LCD Versions Only)

Colonial Weighing Australia Pty Ltd

Unit 11/47-51 Little Boundary Road, Laverton North, Victoria, 3026, Australia

Telephone: (03) 9315 2088
Facsimile: (03) 9315 2494

www.colonialweighing.com.au
sales@colonialweighing.com.au

Established 1930
ISO 9001 Endorsed